

Efficient Serial Communication using Optical Fiber Cable

Miss Rimi Chauhan
ME (Digital Systems)
Trinity College of Engineering & Research,
Pune (MS).
rimi.ch2408@gmail.com

Prof. R. A. Pagare
Dept. of Electronics and Telecommunication
Trinity College of Engineering & Research,
Pune (MS).
rapagare@rediffmail.com

Abstract— The fiber optic option board (F) provides an RS232C serial interface via a fiber optic cable. A fiber optic port is treated the same way as a standard serial port except a fiber optic cable is used for the communications medium. Optical USB Communication protocol is used for long distances which are used for Communication between point to point and point to multipoint. Fiber does not radiate any of the signals it communicates the way copper based transmissions do. Fiber optic networks operate at high speeds. A fiber optic link offers excellent electrical isolation and a high data rate. Two fiber optic cables are required for each fiber optic port. It is also used in many applications such as high speed cable internet access and optical storage systems. We are going to implement and demonstrate prototype of Optical USB (2.0) system for long distances by using PIC microcontroller to a PC via the USB port using fiber.

Index Terms— Serial Communication, PIC Microcontroller, Power supply, Drivers ckt, USB port, Networking

I. INTRODUCTION

Today, the most widely used optical technology is optical fiber for high-speed interconnections, such as in server racks, connecting offices, buildings, metropolitan networks, and even continents via submarine cables. The term "photonics" is taken to cover all applications of light technology, from the ultraviolet part of the spectrum, through the visible, to the near-, mid- and far-infrared. Photonics is increasingly being used in data communication because it provides more ultra-high-capacity and speed in storage, communication and computation[1]. The purpose of this project is to explain how to interface a PIC microcontroller to a PC via the USB port and the concepts are universal. USB is a system for connecting a wide range of peripherals to a computer, including pointing devices, displays, and data storage and communications products. USB 2.0 with a data rate of 480 Mbit/s is commonly used. In this system, an USB host and an USB device are connected via a cable. USB is a system for connecting a wide range of peripherals to a computer, including pointing devices, displays, and data storage and communications products. USB protocol provides communication between computer and peripheral device. Its construction is based on 3

layers:(a)functional, which covers high-level relations between a computer program and a peripheral device,(b)logic, responsible for the flow of data stream, (c)physical, including wires, connections, analog devices.[2] Physical connection consists of 4 wires – 2 for power and 2 for bi-directional differential data transmission. The same set of wires may be shared by up to 127 peripheral devices. USB (Universal Serial Bus) is one of the most widely used interfaces (I/Fs) for consumer electronics devices, such as PCs, digital still cameras, music/video players and various information appliances. [6,7].Currently, three USB versions (1.1,2.0 and 3.0) are available, and USB 2.0 with a data rate of 480 Mbit/s [1] is commonly used for the mobile devices. As USB I/Fs transfer not only data but also a power, USB devices can be driven by a supplied power through the USB I/Fs.[6,7]

In this project, PC is used as data generator. PC contains software like terminal. in which baud rate is set to be 9600bps. If user enters character on PC it will be sent to USB to serial converter. Usb to serial converter is interfaced to PIC microcontroller's serial port. Data received serially in microcontroller will be sent out in the form of 1 0 bits to transmitting LED. Transmitting LED converts data 1 0 bits to ON OFF of light which is transmitted along optical fiber.

At receiver end photo-transistor will convert light into voltage and its sent to signal conditioning ckt. After signal conditioning signal becomes suitable to 0-5V TTL logic and then it can be interfaced to microcontroller..Microcontroller received that data serially and its displays character on LCD.

II. IMPLEMENTATION

Fig.1. We have two sections in this project. One is transmitter and another one is receiver. Transmitter consists of PIC microcontroller board, max232 and LED transmitter circuit. PIC microcontroller is heart of system, which is 8bit microcontroller with low cost and low power feature. PIC microcontroller is initialized with

9600 baud rate. it will receive data from PC via USB (serial converter) and Microcontroller will switch on and off the LED as per data bits. This data is converted in the form of ON OFF pulses and its is carried along by fiber optic cable. At the receiver end we have placed photo-transistor. Light falling on the photo-transistor will get converted into electrical voltage and which is connected to 2nd PIC controller board. This data is simply displayed on LCD. Here we are using 16*2 LCD.

This is how we have received data from USB and have sent it to another controller.

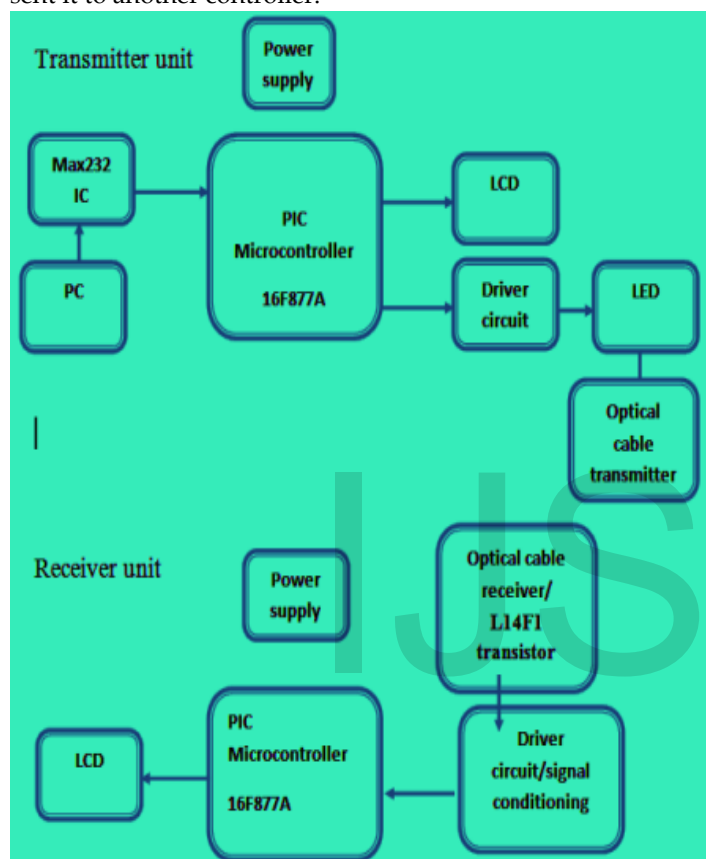

FIG1: Block Diagram of Serial Communication using Optical

III.HARDWARE DESIGN OF Optical USB

A. **Serial Communication:** In general, there are three communication methods used in modern data acquisition systems between computer and peripherals: traditional RS232 serial port, parallel port, and universal high-speed data acquisition card. But not all these methods are ideal. Here are some examples, the transmission speed of RS232 serial port is too low to meet the requirements of real-time, the connection of parallel port is complicated, and high-speed data acquisition card based on ISA or PCI is complex

and expensive. As a standard universal serial interface, the best advantages of USB interface is its high speed, feasibility, support for Plug and Play, and automatic. The USB (Universal Serial Bus) is a fast and flexible interface which can be used to connect electrical devices to a PC, and, as such, has become one of the most popular device interfaces [3]. Its merits are its ease of connection, fast data rate and the fact that most personal computers support it [3]. A serial communications interface (SCI) is a device that enables the serial (one bit at a time) exchange of data between a microprocessor and peripherals such as printers, external drives, scanners, or mic. Serial communication is a communication technique used in telecommunications wherein data transfer occurs by transmitting data one bit at a time in a sequential order over a computer bus or a communication channel. It is the simplest form of communication between a sender and a receiver. Because of the synchronization difficulties involved in parallel communication, along with cable cost, serial communication is considered best for long-distance communication. The SCI contains a parallel-to-serial converter that serves as a data transmitter, and a serial-to-parallel converter that serves as a data receiver.

B. In telecommunication and computer

science: serial communication is the process of sending data one bit at a time, sequentially, over a communication channel or computer bus. Serial communication is used for all long-haul communication and most computer networks, where the cost of cable and synchronization difficulties make parallel communication impractical. Serial computer buses are becoming more common even at shorter distances, as improved signal integrity and transmission speeds in newer serial technologies have begun to outweigh the parallel bus's advantage of simplicity.

C. Flexibility of serial links in communication system design:

Serial links offer significant flexibility over parallel buses in terms of the media used. Both Fibre Channel and Gigabit Ethernet standards specify interfaces to fibre-optic and copper interfaces. Module-based serial connectors can be used, enabling the user to switch between copper and a variety of fibre types simply by switching the module type on a port. For example, the gigabit interface converter

(GBIC) module is a removable, hot-swappable unit that allows easy conversion between media simply by changing the module. This module also allows blind-mating with the receptacle, enabling the user to easily replace (or test) defective modules on a board.

1. PIC16F877 Microcontroller:

8-bit microcontrollers with 40-pins flash microcontrollers that operate in a range 2.0 to 5.5 V at 20 MHz with internal oscillator. It has high performance RISC CPU, interrupt capability, direct, indirect and relative addressing modes, 8K flash Program Memory, 368 bytes of data Memory (RAM), 256 EEPROM data Memory, Programmable code protection, power saving sleep mode, 8-bit analog to digital converters (ADC), serial peripheral interface modules, USART, 3 timers & 5 ports. The microcontroller is well suited for this remote application, because of its low-power consumption, high speed, power on reset facility, in circuit programming & debugging.

2 RS-232 Specifications:

RS 232 is a serial communication cable used in the system. Here, the RS 232 provides the serial communication between the microcontroller and the outside world such as display, PC or Mobile etc. So it is a media used to communicate between microcontroller and the PC. RS-232 is a "complete" standard. This means that the standard sets out to ensure compatibility between the host and peripheral systems by specifying 1) common voltage and signal levels, 2) common pin wiring configurations, and 3) a minimal amount of control information between the host and peripheral systems. Unlike many standards which simply specify the electrical characteristics of a given interface, RS-232 specifies electrical, functional, and mechanical characteristics in order to meet the above three criteria. In our project the RS232 serves the function to transfer the edited notice (or data) from PC (VB software) to the microcontroller, for the further operation of the system.

3. MAX232:

MAX232 is compatible with RS-232 standard, and consists of dual transceiver. Each receiver converts TIA/EIA-232-E levels into 5V TTL/CMOS levels. Each driver converts TTL/ COMS levels into TIA/EIA-232-E levels. The MAX232 is characterized for operation from -40°C to +85°C for all packages. MAX232 is purposed for application in high-performance information processing systems and control devices of wide application.

4. Power Supply:

Microcontroller required 5v dc power supply, We are using is lead acid 12v 1.2Ah battery to achieve this

12VDC is applied to bridge rectifier and filter circuit, then by using fixed regulator IC7805, continuous 5Vdc supply is provided to microcontroller.

5. IC7805:

The 7805 three-terminal positive regulator is available in the TO-220/D-PAK package and 5V fixed output voltage, making them useful in a wide range of applications. Each type employs internal current limiting, thermal shut down and safe operating area protection, making it essentially indestructible. If adequate heat sinking is provided, they can deliver over 1A output current. Although designed primarily as fixed voltage regulators, these devices can be used with external components to obtain adjustable voltages and currents

6. RS-232 specifications

RS 232 is a serial communication cable used in the system. Here, the RS 232 provides the serial communication between the microcontroller and the outside world such as display, PC or Mobile etc. So it is a media used to communicate between microcontroller and the PC.

IV. SOFTWARE DESIGN AND IMPLEMENTATION:

A. BER (Bit-Error-Ratio): Receiver can be determines the logic state of each transmitted bit, where BER is the bit error ratio, $E(t)$ is the number of bits received in error over time t , and $N(t)$ is the total number of bits transmitted in time t . Bit error ratio is a statistical parameter. The measured value depends on the gating time, t , over which the data is collected and on the processes causing the errors.[4,5]

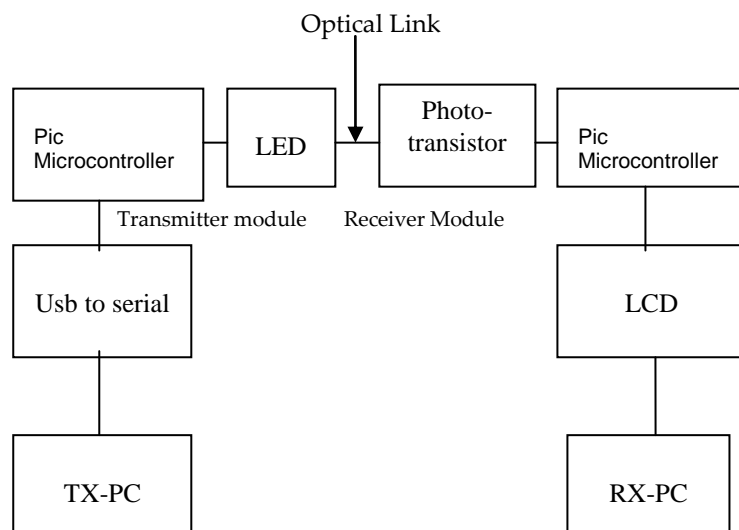

FIG 2. Overview of software design

1. Mikro ICD (In-circuit Debugger): mikro ICD is highly effective tool for **Real-Time debugging** on hardware level. ICD debugger enables you to execute a mikroC program on a host PIC microcontroller and view variable values, Special Function Registers (SFR), memory and EEPROM as the program is running

2. USART:

USART hardware module is available with a number of PIC micros. mikroC USART Library provides comfortable work with the Asynchronous (full duplex) mode. It can easily communicate with other devices via RS232 protocol (for example with PC). We need a PIC MCU with hardware integrated USART, for example PIC16F877.

3. Flash Magic: Flash Magic is Windows software from the Embedded Systems Academy that allows easy access to all the ISP features provided by the device. Flash Magic provides a clear and simple user interface.

V. APPLICATIONS:

1. Fibre optic cables have a much greater bandwidth than metal cables.
2. An optical fibre offers low power loss. This allows for longer transmission distances.
3. Fibre optic cables are much thinner and lighter than metal wires.
4. Fibre optic cables are immune to electromagnetic interference.
5. USB 2.0 increases the productivity of user applications and allows the user to run multiple PC applications at once or several high-performance peripherals simultaneously.
6. USB 2.0 (High-speed USB) provides additional bandwidth for multimedia and storage applications and has a data transmission speed 40 times faster than USB 1.1.

VI. DISADVANTAGES:

1. Cost - Cables are expensive to install but last longer than copper cables.
2. Transmission - transmission on optical fibre requires repeating at distance intervals.
3. Fragile - Fibres can be broken or have transmission losses when wrapped around curves of only a few centimetres radius.
4. Protection - Optical fibres require more protection around the cable compared to copper.

VII. Algorithm

1. Initialize serial port at laptop end with baud rate of 9600
2. Open the serial port
3. Initialize both the transmitter and receiver sections with baud rate 9600
4. Check for the data to be received at transmitter section
5. If data received, transmit the same data serially to optical end
6. At receiver section, check for the data to be received
7. If data received, transmit the same data serially to PC
8. Process continues till power supply is ON

VIII. EXPERIMENTAL SET UP / IMPLEMENTATIONS:

.Microcontroller received the data serially and it displays character on LCD.

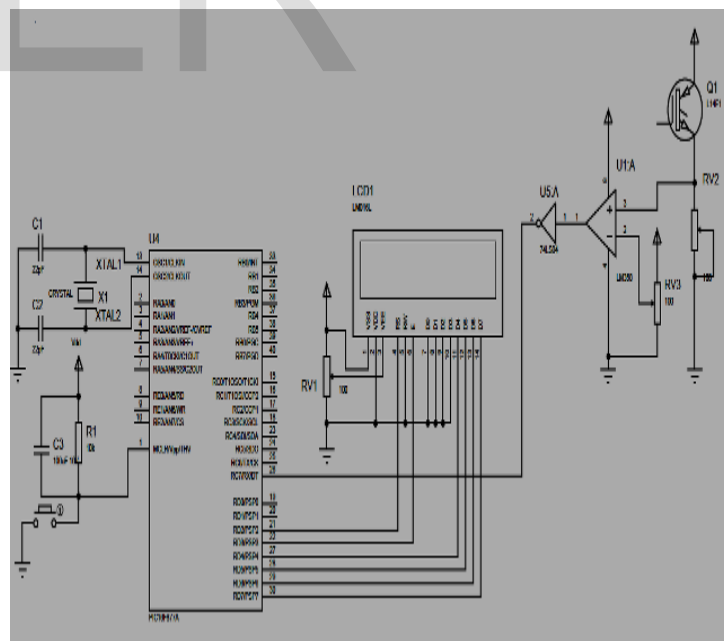

FIG 3. Overview of Hardware Implementations.

IX. Results:

PC is used as data generator. PC contains software like terminal. in which baud rate is set to be 9600bps. If user enters character on pc it will be sent to USB to serial converter. Usb to serial converter is interfaced to PIC microcontroller's serial port.

X..CONCLUSION

By using Optical USB Protocol, we can communicate two devices for upto long distances. We can measure the data for long distances. We can implement low cost yet highly efficient Optical fiber System for USB communications.

ACKNOWLEDGMENTS

The goal of this paper is to design "Efficient Serial Communications using Optical Fiber Cable" The function has been realized successfully. I wish to place on record my sincere thanks and whole hearted thanks to my guide Prof. R. A. Pagare under whose supervision this dissertation work has been carried out. It was his keen interest encouraging disposition and full co-operation that has made it possible for me to complete this work. I wish to place on record my sincere thanks and also acknowledge my indebtedness to Prof. Hendre V.S., Head of Electronics & Telecommunication Department, whose critical analysis careful comments and valuable suggestions have been immense help in completing this work. Lastly, I am thankful to all those persons, who have contributed directly or indirectly in the completion of this project.



Miss Rimi Chauhan

Student of M.E(Digital System)- Trinity College of Engineering & Research, Pune.

B.E-North Maharastra University-2012.

HSC-CBSE Board-2008 & SSC-Mizoram Board-2006



Prof R.A. PAGARE (Dept. of Electronics and Telecommunication) Trinity College of Engineering Research, Pune.

UG-MIT Aurangabad. & PG-SGGS Nanded.

11 Years of teaching experienced.

2-IEEE Explorer & 2-International Conference

4-National Conference.& 2-National journals.

2-International journals.

REFERENCES

- [1]Paramjeet kaur ,Er. Hardeep Singh ,Er.Satinder pal Ahuja. (Review of Optical World Technologies and Switching Network Devices). International Journal of Advanced Research in Computer Science and Software Engineering Department of Computer Science and Engineering Indo Global College of Engineering, Abhipur (P.B) – 140109,India. Volume 2, Issue 2, February 2012 ISSN: 2277 128X
- [2] Przemyslaw M. Szczówka, Kamil J. Pyrzynski (USB Receiver/Transmitter for FPGA Implementation) Faculty of Microsystem Electronics and Photonics, Wroclaw University of Technology Wroclaw, Poland, ICSES 2012 – International Conference on Signals and Electronic Systems WROCLAW, POLAND, September 18 – 21, 2012
- [3] Zhang Ting, Jiang Li and Li Nan (A measurement and control system based onUSB bus for prosthetic hand) State Key Laboratory of Robotics and System Institute of Robotics and Mechatronics Harbin Institute of Technology German Aerospace Center Harbin 150001, P. R. China, 2011 IEEE International Conference on Mechatronics and Automation August 7 - 10, Beijing, China
- [4] James C.daly," Fibre Optics", CRC press, 1984.
- [5]Dennis Derickson, "Fibre Optic Test and Measurement," Prentice Hall, 1998
- [6] Tomonori Yazaki, Itsuro Morita and Hideaki Tanaka(Optical Wireless USB 2.0 System with 1 Gbit/s Optical Transceiver) KDDI R&D Laboratories Inc. 2-1-15 Ohara Fujimino-shi, Saitama 356-8502, Japan, 15th OptoElectronics and Communications Conference (OECC2010) Technical Digest, July 2010, Sapporo Convention Center, Japan.
- [7] Tomonori Yazaki, Itsuro Morita and Hideaki Tanaka(Demonstration of Optical Wireless USB 2.0 System with Wireless Power Transfer) KDDI R&D Laboratories Inc.2-1-15 Ohara Fujimino-shi, Saitama 356-8502, Japan, 2011 IEEE International Conference on Consumer Electronics (ICCE).
- [8] Ragne Emardson, Per Olof Hedekvist, Mattias Nilsson, Sven-Christian Ebenhag, Kenneth Jaldehag, Per Jarlemark,Carsten Rieck, Jan Johansson, Leslie R. Pendrill, Peter Löthberg, and Håkan Nilsson"Time Transfer by Passive Listening Over a 10-Gb/s Optical Fiber"IEEE TRANSACTIONS ON INSTRUMENTATION AND MEASUREMENT, VOL. 57, NO. 11, NOVEMBER 2008
- [9]Rajiv Ramaswami "Optical Fiber Communications from transmission to networking"IEEE Communications Magazine 50th Anniversary Commemorative Issue May/2002